



MOTORPUMP™ — 3500 RPM

60 HERTZ, 2.5 X 2.5 X 6.5 ANSI FLG

54F

JM

MOTOR DIMENSIONS

NEMA JM FRAME 3 PHASE 3500 RPM

HP	Type	Frame	D	E	F	O	AB	BG	L	MH
5	ODP	JM182	4.50	3.75	2.25	8.31	6.58	4.84	5.27	0.41
7.5	ODP	JM184	4.50	3.75	2.75	8.31	6.58	5.34	5.56	0.41
10	ODP	JM213	5.25	4.25	2.75	9.84	6.80	6.00	6.82	0.41
15	ODP	JM215	5.25	4.25	3.50	9.84	6.80	6.75	6.07	0.41
5/7.5	TEFC	JM184	4.50	3.75	2.75	8.85	7.09	5.51	7.64	0.41
10/15	TEFC	JM215	5.25	4.25	3.50	10.37	8.19	6.77	9.08	0.41

D054FJM184

DRAWING DEPICTS 7.5 HP JM184 ODP MOTOR

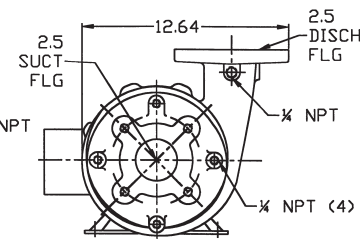
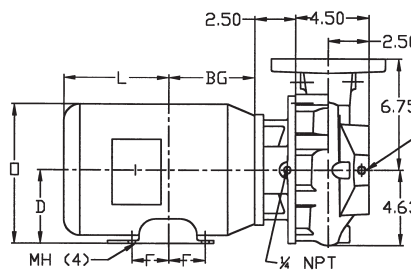
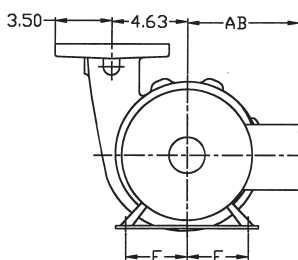

ALL DIMENSIONS IN INCHES.

DRAWING REPRESENTS APPROXIMATE PUMP DIMENSIONS. AUTOCAD DRAWING TO SCALE AVAILABLE FROM FACTORY.

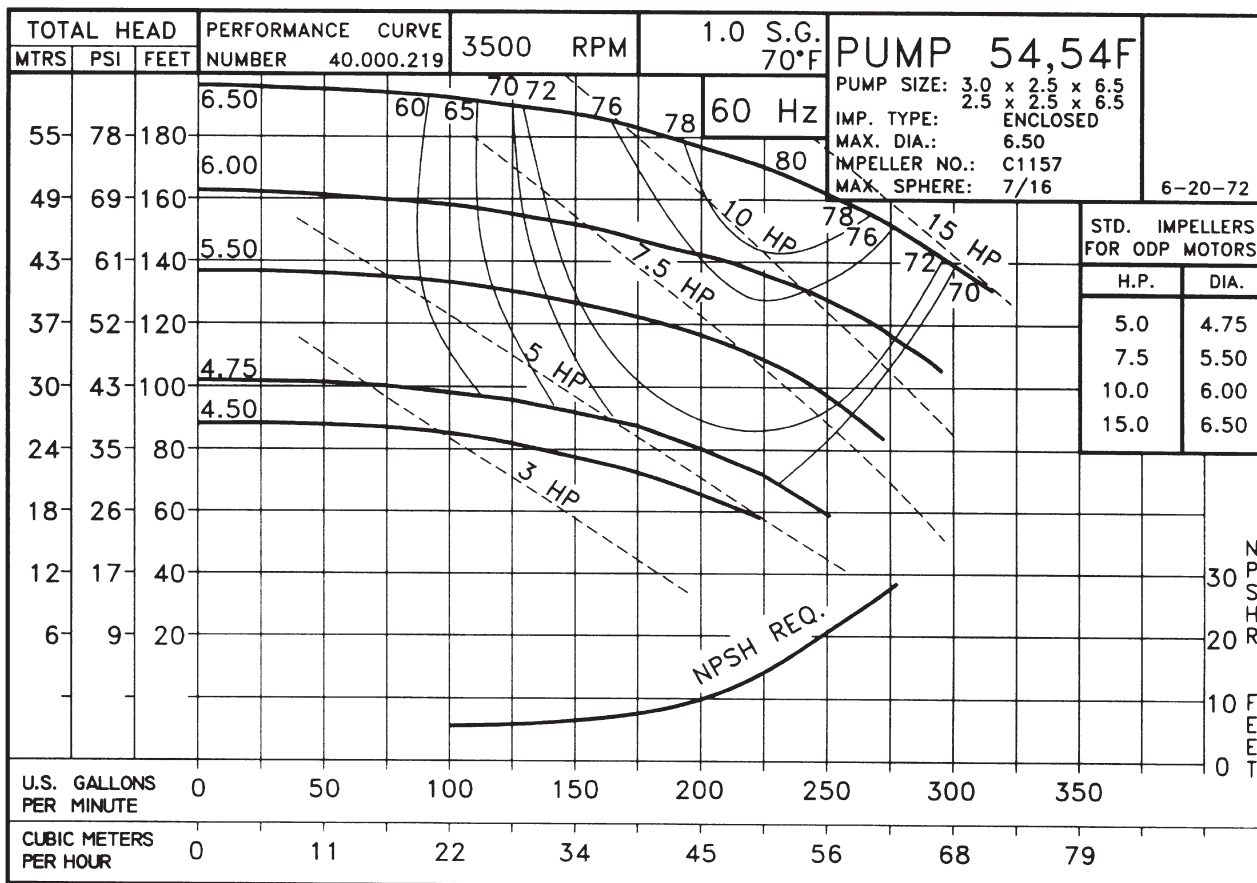

054F10DP D054FJM184
0543500

54F

JM

054F3500JM
81.000.910A G5

Pump 54F • Iron • JM Frame • 3500 RPM

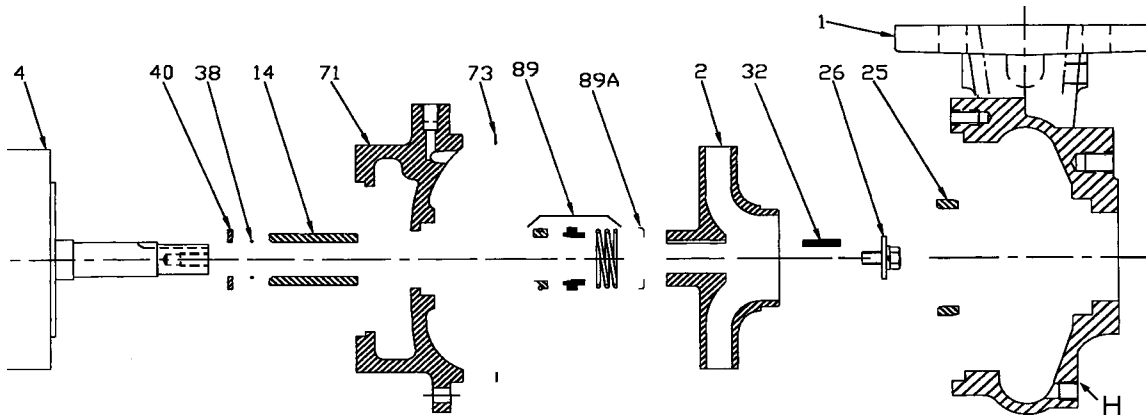

054FJM

KEY NO.	PART NAME	PUMP NO. 54F
1+	CASE, IRON, 2.5 x 2.5 FLG	130.000.184X
2	IMPELLER, 7/8" KEYED, ENCLOSED, SPECIFY DIAMETER:	
	IRON	131.000.812
	BRONZE	131.000.825
4	MOTOR, JM140/180	See Chart
	MOTOR, JM210	See Chart
14*	SHAFT SLEEVE, BRONZE	110.000.178
	SHAFT SLEEVE, STAINLESS	110.000.192
25	WEAR RING, BRONZE	103.000.137
	WEAR RING, STEEL	103.000.153
26*	IMPELLER RETAINER, STAINLESS	118.000.163A
32*	KEY, STAINLESS	102.000.102
38*	O-RING, SHAFT, BUNA	116.000.117
	O-RING, SHAFT, VITON	116.000.105
40*	FLINGER, STAINLESS	104.000.165
71	ADAPTER, IRON - JM140/180	132.000.202
	ADAPTER, IRON - JM210	132.000.213
73*	GASKET, CASE, FIBER	116.000.157
89*	1½" SEALS:	
	BN-CARB/CM	101.000.168
	VN-CARB/CM	101.000.191
	VN-CARB/SIL	101.000.175
	VN-SIL/SIL	101.000.204
	EPDM-CARB/SIL	101.000.175B
	EPDM-SIL/SIL	101.000.204A
89A*	SEAL RETAINER, STAINLESS	104.000.174
--	° REPAIR KITS:	
	BN-CARB/CM SEAL	118.000.344
	VN-CARB/CM SEAL (S)	118.000.344A
	VN-CARB/CM SEAL	118.000.344K
	VN-CARB/SIL SEAL	118.000.344B
	VN-SIL/SIL SEAL (S)	118.000.344F
	EPDM-CARB/SIL SEAL	118.000.344C
EPDM-SIL/SIL SEAL	118.000.344D	

* DENOTES COMPONENTS INCLUDED IN REPAIR KIT.
 + INCLUDES BRONZE WEAR RING. FOR STEEL WEAR RING, REPLACE SUFFIX "X" WITH "X1".
 ° ALL REPAIR KITS INCLUDE THE BRONZE SHAFT SLEEVE EXCEPT THE (S) INDICATED, WHICH IS STAINLESS WITH VITON SHAFT O-RING.

Pump 54F • Iron • JM Frame • 3500 RPM

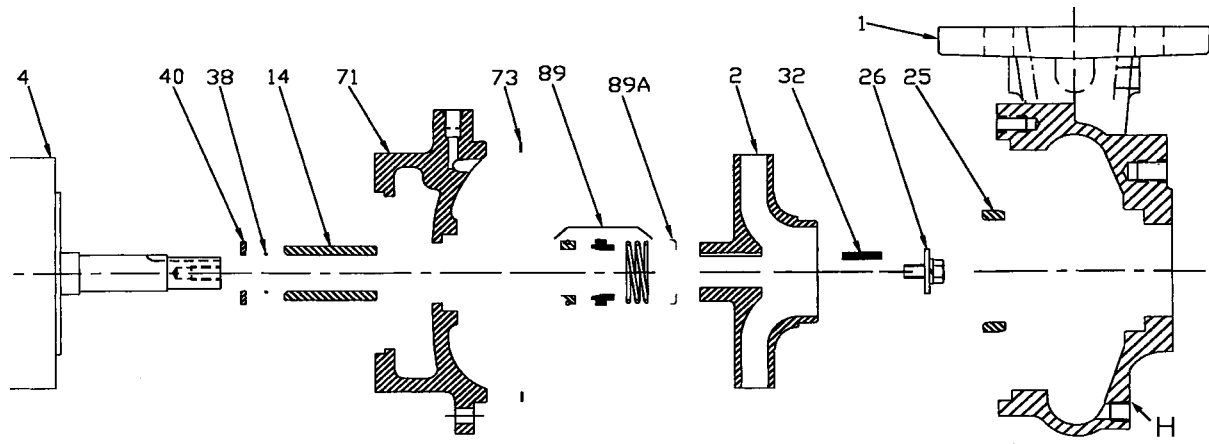

054FJM

CONSTRUCTION OPTIONS				
KEY	PART NAME	STANDARD FITTED	BRONZE FITTED	ALL IRON
1	Case	Iron	Iron	Iron
2	Impeller	Iron	Bronze	Iron
14	Shaft Sleeve	Bronze	Bronze	Stainless
25	Wear Ring	Bronze	Bronze	Steel
26	Impeller Retaining Assy	Stainless	Stainless	Stainless
32	Key	Stainless	Stainless	Stainless
38	Shaft O-Ring	BUNA	BUNA	BUNA
40	Flinger	Stainless	Stainless	Stainless
71	Adapter	Iron	Iron	Iron
73	Gasket, Case	Fiber	Fiber	Fiber
89	Mechanical Seal, Type 21 BN-CM	Standard	Standard	Standard
89A	Seal Spring Retainer	Stainless	Stainless	Stainless
H	Plug, Drain	Brass	Brass	Plated Steel