

Pump 56F • Iron • JM Frame • 3500 RPM

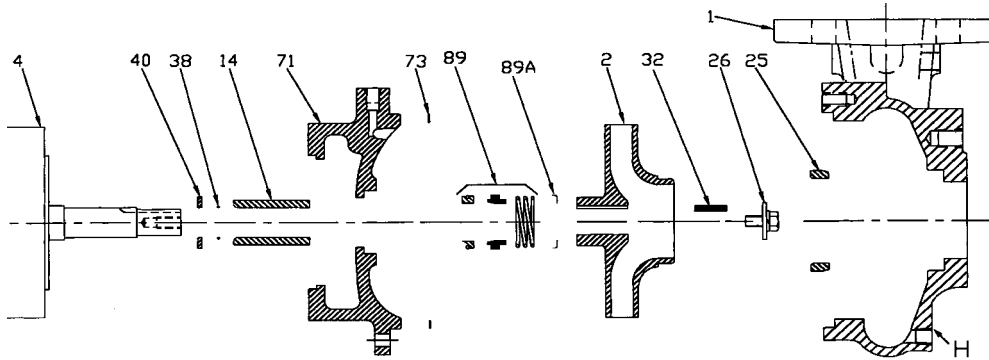

054FJM

KEY NO.	PART NAME	PUMP NO. 56F	
		7.5 - 15 HP	20 - 30 HP
1+	CASE, IRON, 3 x 3 FLG	130.000.185X	130.000.185X
2	IMPELLER, ENCLOSED, SPECIFY DIAMETER:	7/8" KEYED	1 1/4" KEYED
	IRON	131.000.809	131.000.824
	BRONZE	137.000.108	137.000.109
4	MOTOR, JM140/180	See Chart	--
	MOTOR, JM210	See Chart	--
	MOTOR, JM250	--	See Chart
	MOTOR, JM280/320	--	See Chart
14*	SHAFT SLEEVE, BRONZE	110.000.178	110.000.248
	SHAFT SLEEVE, STAINLESS	110.000.192	110.000.261
25	WEAR RING, BRONZE	103.000.138	103.000.138
	WEAR RING, STEEL	103.000.152	103.000.152
26*	IMPELLER RETAINER, STAINLESS	118.000.163A	118.000.234
32*	KEY, STAINLESS	102.000.102	102.000.208
38*	O-RING, SHAFT, BUNA	116.000.117	116.000.218
	O-RING, SHAFT, VITON	116.000.105	116.000.218A
40*	FLINGER, STAINLESS	104.000.165	104.000.200
71	ADAPTER, IRON - JM140/180	132.000.202	--
	ADAPTER, IRON - JM210	132.000.213	--
	ADAPTER, IRON - JM250	--	132.000.245
	ADAPTER, IRON - JM280/320	--	132.000.246
73*	GASKET, CASE, FIBER	116.000.157	116.000.157
89*	SEALS:	1 1/2"	1 3/4"
	BN-CARB/CM	101.000.168	101.000.196
	VN-CARB/CM	101.000.191	101.000.216
	VN-CARB/NR	Use CARB/SIL	101.000.221
	VN-CARB/SIL	101.000.175	Use CARB/NR
	VN-SIL/SIL	101.000.204	101.000.231
	EPDM-CARB/NR	Use CARB/SIL	101.000.196B
	EPDM-CARB/SIL	101.000.175B	Use CARB/NR
	EPDM-SIL/SIL	101.000.204A	137.001.555
89A*	SEAL RETAINER, STAINLESS	104.000.174	Included w/seal
--	° REPAIR KITS:		
	BN-CARB/CM SEAL	118.000.344	118.000.345
	VN-CARB/CM SEAL (S)	118.000.344A	118.000.345A
	VN-CARB/CM SEAL	118.000.344K	118.000.345E
	VN-CARB/NR SEAL	Use CARB/SIL	118.000.345B
	VN-CARB/SIL SEAL	118.000.344B	Use CARB/NR
	VN-SIL/SIL SEAL (S)	118.000.344F	118.000.345C
	EPDM-CARB/NR SEAL	Use CARB/SIL	118.000.345F
	EPDM-CARB/SIL SEAL	118.000.344C	Use CARB/NR
EPDM-SIL/SIL SEAL	118.000.344D	118.000.345G	

* DENOTES COMPONENTS INCLUDED IN REPAIR KIT.

+ INCLUDES BRONZE WEAR RING. FOR STEEL WEAR RING, REPLACE SUFFIX "X" WITH "X1".

° ALL REPAIR KITS INCLUDE THE BRONZE SHAFT SLEEVE EXCEPT THE (S) INDICATED, WHICH IS STAINLESS WITH VITON SHAFT O-RING.

Pump 56F • Iron • JM Frame • 3500 RPM

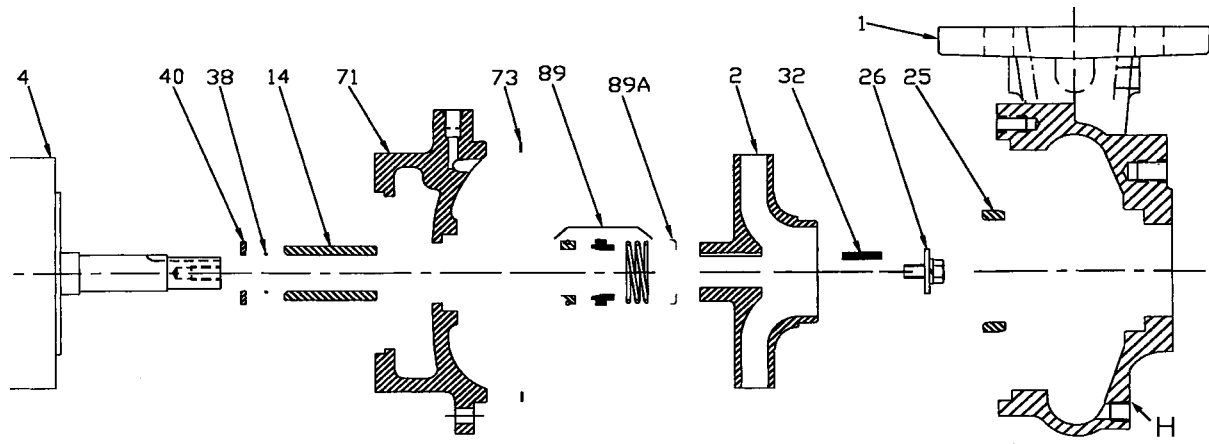

054FJM

CONSTRUCTION OPTIONS				
KEY	PART NAME	STANDARD FITTED	BRONZE FITTED	ALL IRON
1	Case	Iron	Iron	Iron
2	Impeller	Iron	Bronze	Iron
14	Shaft Sleeve	Bronze	Bronze	Stainless
25	Wear Ring	Bronze	Bronze	Steel
26	Impeller Retaining Assy	Stainless	Stainless	Stainless
32	Key	Stainless	Stainless	Stainless
38	Shaft O-Ring	BUNA	BUNA	BUNA
40	Flinger	Stainless	Stainless	Stainless
71	Adapter	Iron	Iron	Iron
73	Gasket, Case	Fiber	Fiber	Fiber
89	Mechanical Seal, Type 21 BN-CM	Standard	Standard	Standard
89A*	Seal Spring Retainer	Stainless	Stainless	Stainless
H	Plug, Drain	Brass	Brass	Plated Steel

* Included with seal on 20-25 HP