



MOTORPUMP™ — 1750 RPM

60 HERTZ, 6 X 5 X 10 ANSI FLG

96
JP

MOTOR DIMENSIONS

NEMA JP FRAME 3 PHASE 1750 RPM

HP	Type	Frame	D	E	F	O	AB	BG	L	MH
15	ODP	JP254	6.22	5.00	4.13	12.20	9.76	8.13	8.54	0.53
20	ODP	JP256	6.22	5.00	5.00	12.20	9.76	9.00	9.40	0.53
25	ODP	JP284	7.00	5.50	4.75	13.86	10.55	9.25	9.51	0.53
30	ODP	JP286	7.00	5.50	5.50	13.86	10.55	10.00	10.25	0.53
15	TEFC	JP254	6.25	5.00	4.13	12.37	10.19	8.14	10.82	0.53
20	TEFC	JP256	6.25	5.00	5.00	12.37	10.19	9.01	11.70	0.53
25	TEFC	JP284	7.00	5.50	4.75	13.93	10.89	9.27	12.29	0.53
30	TEFC	JP286	7.00	5.50	5.50	13.93	10.89	10.02	13.04	0.53

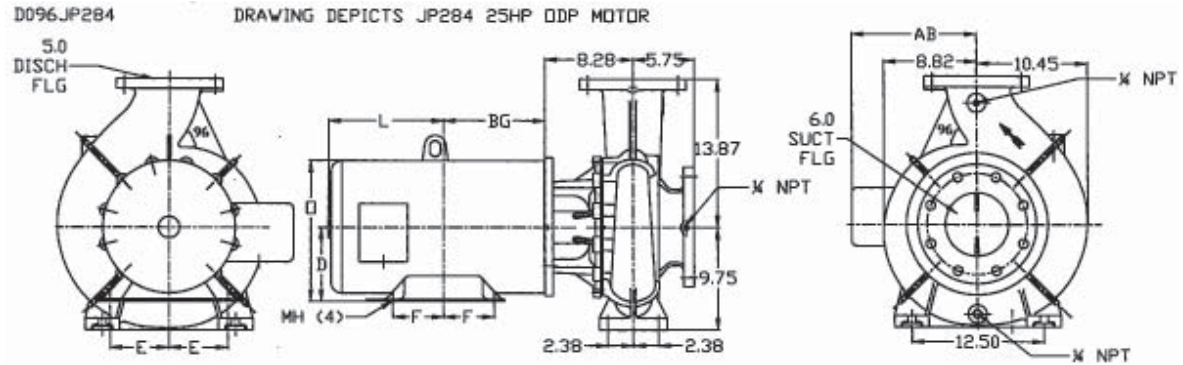

ALL DIMENSIONS IN INCHES.
DRAWING REPRESENTS APPROXIMATE PUMP DIMENSIONS. AUTOCAD DRAWING TO SCALE AVAILABLE FROM FACTORY.

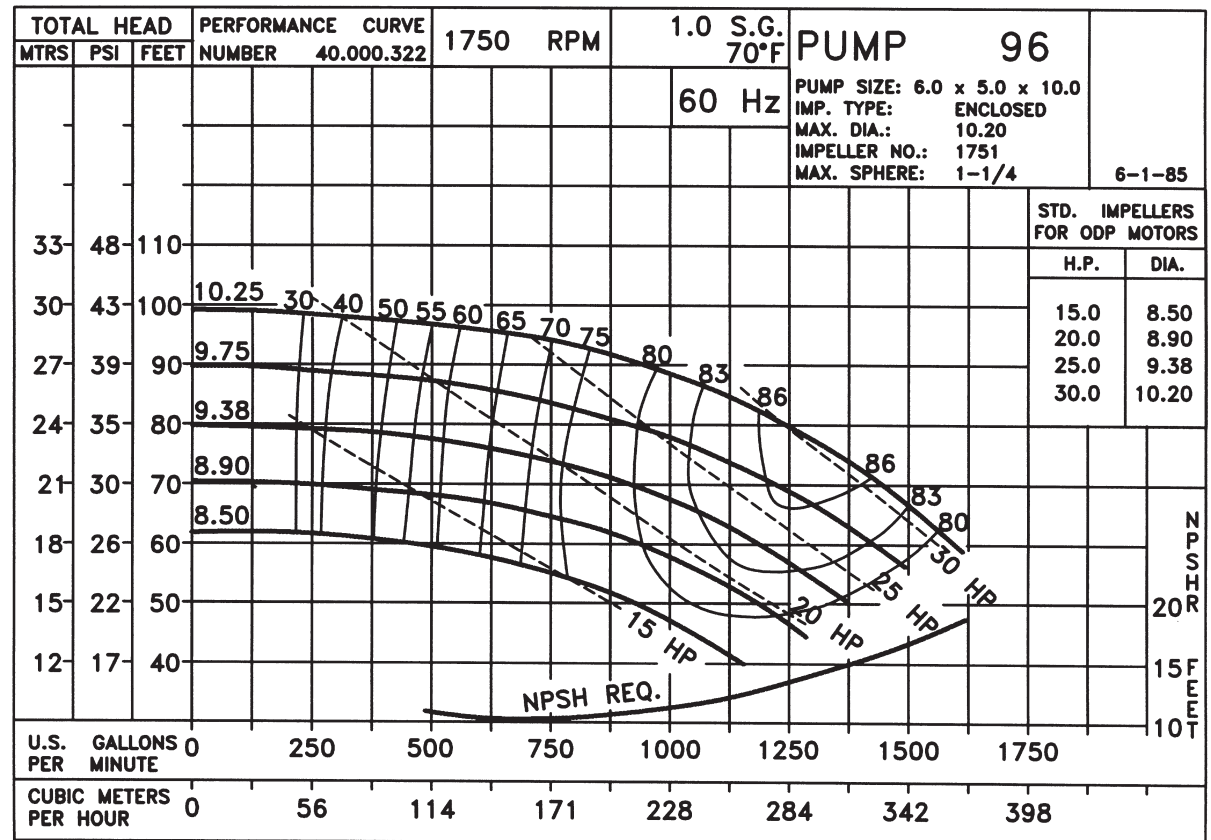

09615TE D096JP284
0961750

96
JP

0961750JP
81.000.907 G5

Pump 96 • Iron • JP Frame • 1750 RPM

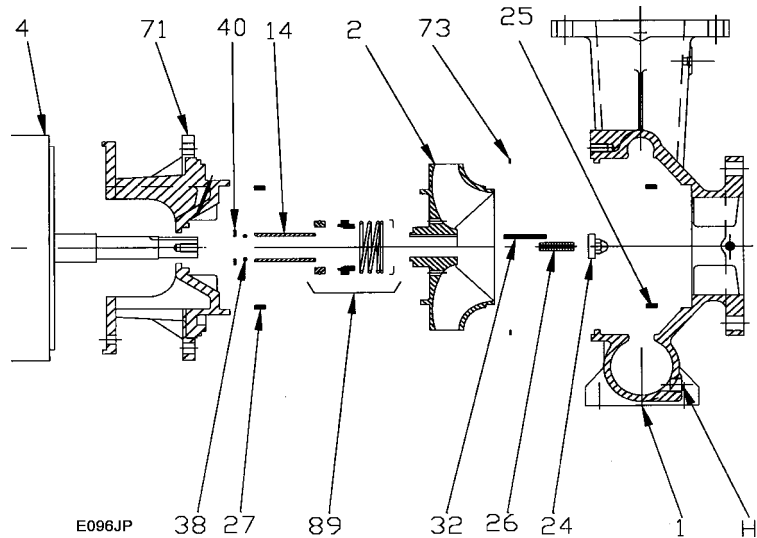

KEY NO.	PART NAME	PUMP NO. 96
1+	CASE, IRON, 6 x 5 FLG	130.000.372X
2	IMPELLER, 1 1/4" KEYED, ENCLOSED, SPECIFY DIAMETER:	
	IRON	137.000.149
4	MOTOR, JP210/250	See Chart
	MOTOR, JP280/320	See Chart
14*	SHAFT SLEEVE, BRONZE	110.000.398
	SHAFT SLEEVE, STAINLESS	110.000.360
24*	NUT, BRONZE	137.000.406
	NUT, STAINLESS	110.000.304
25	WEAR RING, CASE, BRONZE	103.000.199
	WEAR RING, CASE, STEEL	103.000.194
26*	STUD, STAINLESS	105.000.484
27	WEAR RING, ADAPTER, BRONZE	103.000.199
	WEAR RING, ADAPTER, STEEL	103.000.194
32*	KEY, STAINLESS	102.000.284
38*	O-RING, SHAFT, BUNA	116.000.218
	O-RING, SHAFT, VITON	116.000.218A
40*	FLINGER, STAINLESS	104.000.200
71+	ADAPTER, IRON, JP210/250	132.000.357X
	ADAPTER, IRON, JP280/320	132.000.362X
73*	GASKET, CASE, FIBER	116.000.267
89*	1 3/4" SEALS:	
	BN-CARB/CM	101.000.196
	VN-CARB/CM	101.000.216
	VN-CARB/NR	101.000.221
	VN-SIL/SIL	101.000.231
	EPDM-CARB/NR	101.000.196B
--	° REPAIR KITS:	
	BN-CARB/CM SEAL	118.000.405
	VN-CARB/CM SEAL (S)	118.000.405A
	VN-CARB/NR SEAL	118.000.405B
	VN-SIL/SIL SEAL (S)	118.000.405D
	EPDM-CARB/NR SEAL	118.000.405C
	EPDM-SIL/SIL SEAL	118.000.405E

Pump 96 • Iron • JP Frame • 1750 RPM

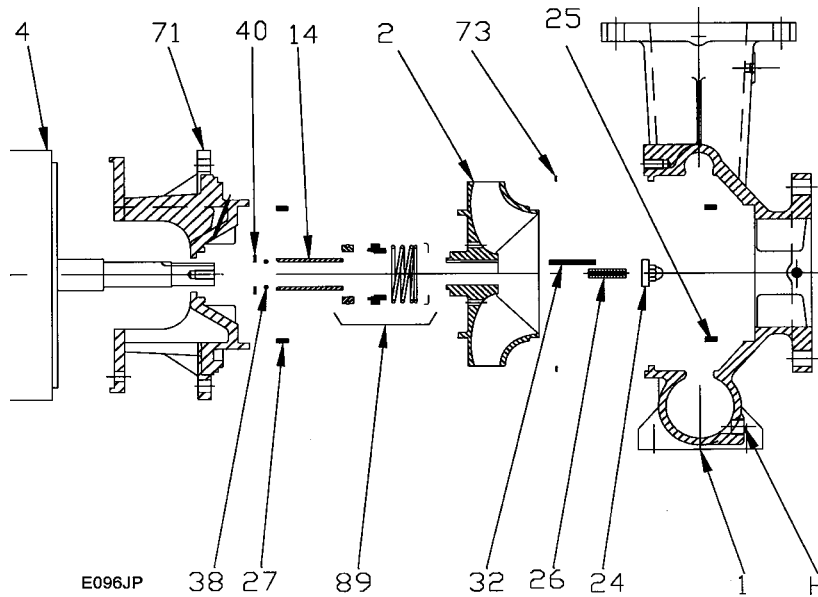

CONSTRUCTION OPTIONS

KEY	PART NAME	STANDARD FITTED	BRONZE FITTED	ALL IRON
1	Case	Iron	Iron	Iron
2	Impeller	Iron	Bronze	Iron
14	Shaft Sleeve	Bronze	Bronze	Stainless
24	Nut	Bronze	Bronze	Stainless
25	Wear Ring, Case	Bronze	Bronze	Steel
26	Stud	Stainless	Stainless	Stainless
27	Wear Ring, Adapter	Bronze	Bronze	Steel
32	Key	Stainless	Stainless	Stainless
38	Shaft O-Ring	BUNA	BUNA	BUNA
40	Flinger	Stainless	Stainless	Stainless
71	Adapter	Iron	Iron	Iron
73	Gasket, Case	Fiber	Fiber	Fiber
89	Mechanical Seal, Type 21 BN-CM	Standard	Standard	Standard
H	Plug, Drain	Brass	Brass	Plated Steel